

netPower 16P

The NetPower is a weatherproof switch with capability of delivering PoE to your connected devices.

Quickstart

Please follow these quick steps to set up your device:

- Open the bottom lid (see [“Bottom Lid”](#));
- Connect all served devices to Ethernet ports;
- Connect the device to the power source (see [“Powering”](#));
- Once connected to the same network, open <http://192.168.88.1> in your web browser to start configuration, user name: *admin* and there is no password by default;
- We recommend clicking the “Check for updates” button and updating your software to the latest version to ensure the best performance and stability;
- Set up your password on the screen that loads.

Expansion slots and ports

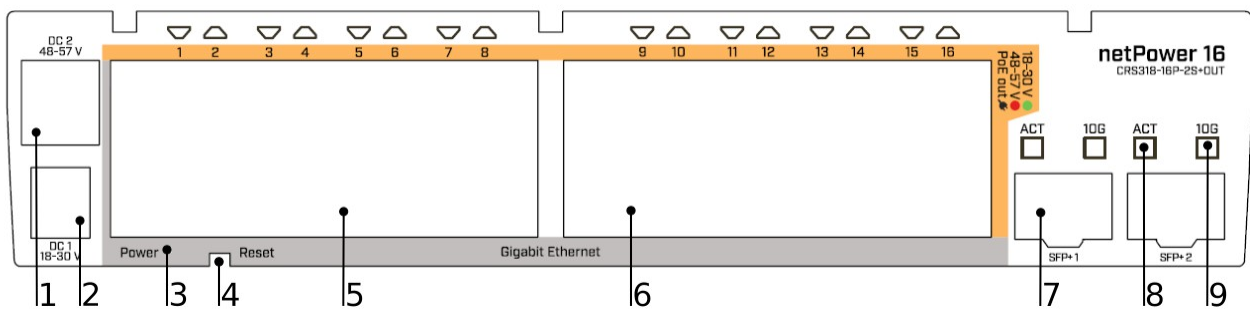

1. DC power connector 48 – 57 V.
2. DC power connector 18 – 30 V.
3. LED indicating a power state of the device.
4. Reset button.
5. Gigabit Ethernet, 8 - ports, delivering PoE out.
6. Gigabit Ethernet, 8 - ports, delivering PoE out.
7. Two - 10G SFP+ ports.
8. LED Indicating the activity of SFP port.
9. LED Indicating the speed of SFP port.

Configuration

The device can be discovered using Winbox utility, by clicking on the Neighbors list. The default management address is 192.168.88.1. To reach both devices needs to be in the same IP network. Configured as a bridge, ARP and fast forward enabled. RSTP protocol activated.

RouterOS includes many configuration options in addition to what is described in this document. We suggest starting here to get yourself accustomed to the possibilities: <http://mt.lv/help>.

For recovery purposes, it is possible to boot the device for reinstallation, see section [Buttons and Jumpers](#).

Powering

The device accepts power in the two ways following ways:

- Direct-input power jack 1, (5.5 mm outside and 2 mm inside, female, pin positive plug) accepts 18-30 V DC.
- Direct-input power jack 2, 48-57 V DC.

Use included DC plug to connect with your power source:

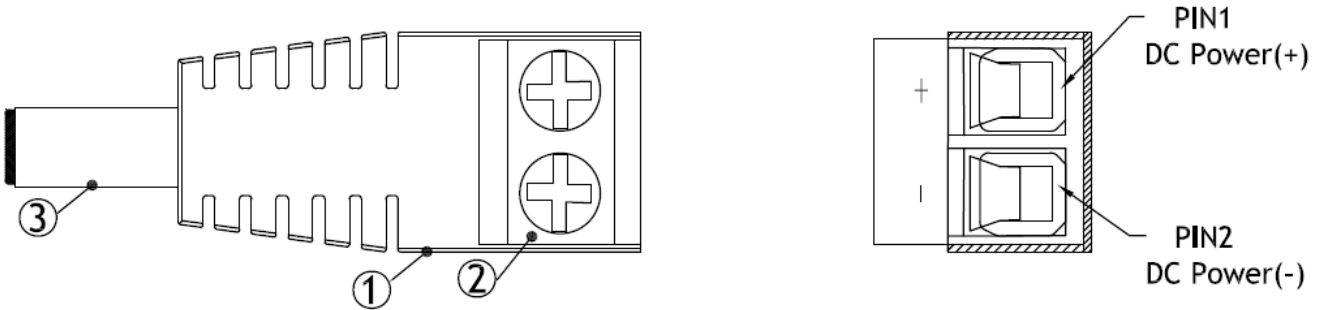

1. DC plug 2.1x5.5x12 mm to Screw Terminal 2pin.
2. Connect your power source cables to the two pins and secure them in place by tightening screws.
3. Connect DC plug to the device.

The power consumption under maximum load can reach 21 W, with attachments 325 W.

Power output

The device supports 802.3af/at PoE from Ethernet 1 - 16. You can power Mikrotik devices which supports powering through Ethernet. The power delivered through the PoE port will depend on the incoming to the device.

- Max out per port when input greater than 30 V - 1.1 A.
- Max out per port when input lower than 30 V – 0.6 A.
- Max total out 2.8 A.

Connecting to a PoE Adapter, only to deliver power to other devices:

1. Connect the Ethernet cable from the device to the PoE+DATA port of the PoE adapter.
2. Connect an Ethernet cable from your local network (LAN) to the PoE adapter.
3. Connect the power cord to the adapter, and then plug the power cord into a power outlet.

Bottom Lid

1. Bottom lid is secured in place with the captive screw, it can be unscrewed by hand, but do not remove the screw completely.
2. Pull the cover towards.

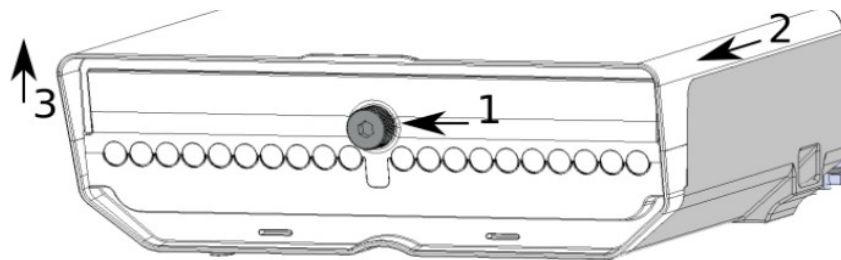

3. Lift to access Ethernet ports.

Mounting

The device can be mounted in several ways: pole, wall or ceiling. The package also includes a drill hole template with detailed mounting instructions, to help you with the drill hole marking. The device has eight mounting points for versatility use zip ties or steel clamps for mounting on the pole.



The IP rating scale for this device is IP54. When mounting outdoors, please ensure that any cable openings are directed downwards. We recommend using the POE injector and proper grounding with Cat6 shielded cable.

Mounting points:

- There are eight mounting points on the back of this device. Choose the most relevant ones.
- Middle points are designed for mounting on the mast, there is curves on the case for slim fitment.



It's recommended to secure Ethernet cable to the pole using zip ties. With the distance from the device approximately 30 cm.

The device must be mounted by UP arrow facing upwards.

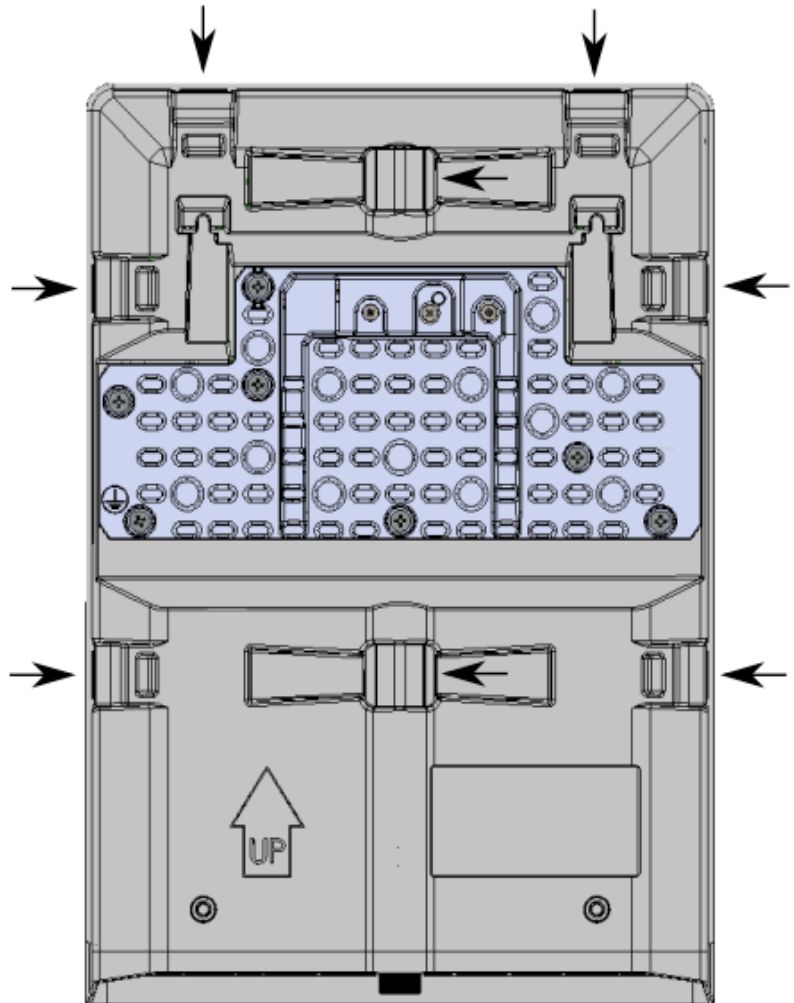

The installation infrastructure (towers and masts), as well as the router itself, must be properly grounded. The device includes a grounding wire attachment screw on the backside.

- Attach your grounding wire to the grounding screw.
- Attach the other end of the grounding wire to the grounded mast.

Mounting and configuration of this device should be performed by a qualified person.

Mounting on the mast or pole:

1. Insert provided steel clamps into mounting spots.
2. Attach the unit to the mast.
3. Align the device and secure it by tightening steel clamps with a PH2 screwdriver.
4. Guide Ethernet cables through the opening and connect to the Ethernet ports.
5. Close bottom latch and secure with a screw.

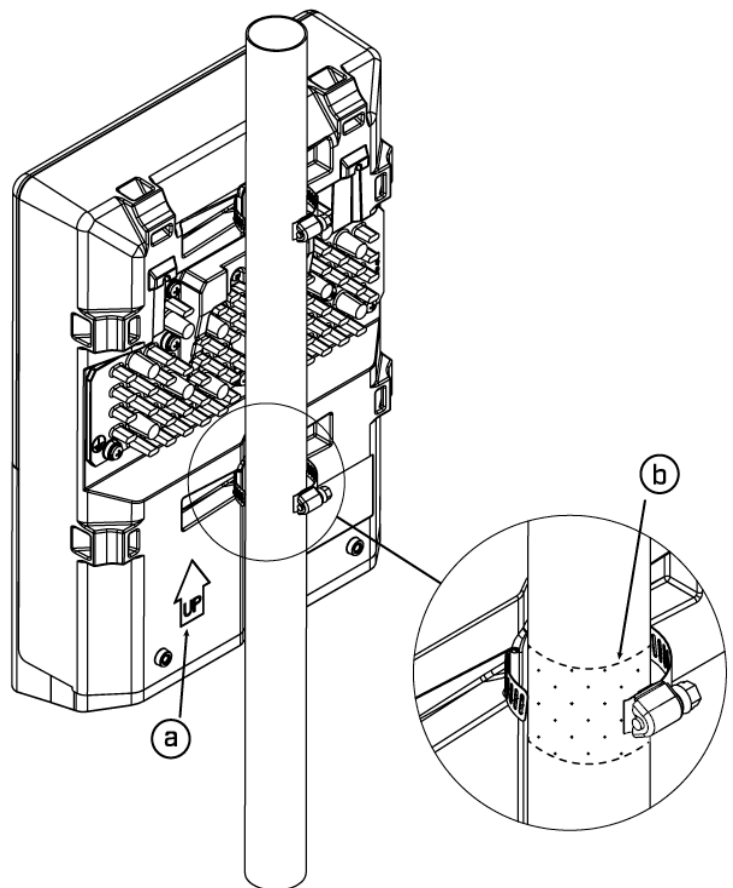

A – Always make sure to place the unit in upwards position.

B - It's recommended to use electrical tape to increase friction between materials.

Mounting unit on the wall:

1. Use included a template to mark spots for drilling holes. Align accordingly, it will depend on how the device will be mounted finally.
2. Insert dowels if needed, depends on wall structure and material.
3. Insert screws and screw them by leaving approximately 1 cm out.
4. Attach the unit to the position.
5. Use screw holes under the bottom cover and tighten to secure in place. Extend your Ethernet cables through the openings and connect to Ethernet ports.
6. Close bottom latch.

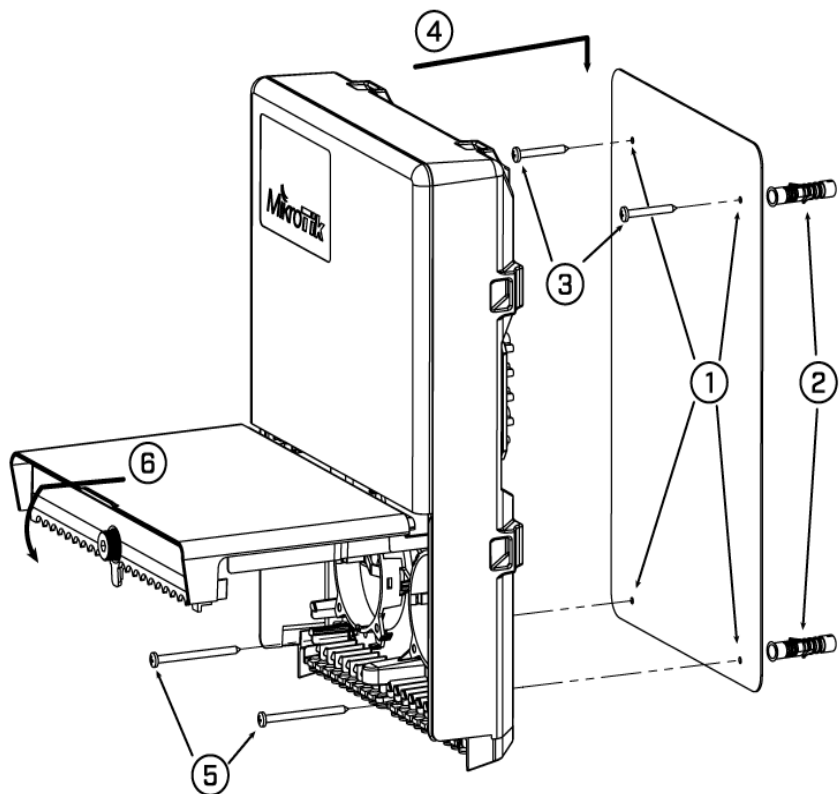

Carefully check the wall for electric cables before drilling mounting holes.

Buttons and jumpers

The RouterBOOT reset button has the following functions. Press the button and apply the power, then:

- Release the button when a green LED starts flashing, to reset RouterOS configuration to defaults.
- Release the button when the LED turns solid green to clear all configuration and bridge all interfaces.
- Release the button after LED is no longer lit (~20 seconds) to cause a device to look for Netinstall servers (required for reinstalling RouterOS over the network).

Regardless of the above option used, the system will load the backup RouterBOOT loader if the button is pressed before power is applied to the device. Useful for RouterBOOT debugging and recovery.

Accessories

Package includes the following accessories that come with the device:

- DC plug 2.1x5.5x12 mm to Screw Terminal 2pin AWG14-20 Adapter.
- Hose Clamp SUS304.
- K-66 fastening set.
- OED-drill-template, paper brochure.

Specifications

For more information about this product, specification and pictures please visit our web page:

https://mikrotik.com/product/netpower_16P

Operating system support

The device supports RouterOS software version 6.45.3. The specific factory installed version number is indicated in the RouterOS menu `/system resource`. Other operating systems have not been tested.

Federal Communication Commission Interference Statement

This equipment has been tested and found to comply with the limits for a Class B digital device, pursuant to Part 15 of the FCC Rules. These limits are designed to provide reasonable protection against harmful interference in a residential installation.

This equipment generates, uses and can radiate radio frequency energy and, if not installed and used in accordance with the instructions, may cause harmful interference to radio communications. However, there is no guarantee that interference will not occur in a particular installation. If this equipment does cause harmful interference to radio or television reception, which can be determined by turning the equipment off and on, the user is encouraged to try to correct the interference by one of the following measures:

- Reorient or relocate the receiving antenna.
- Increase the separation between the equipment and receiver.
- Connect the equipment into an outlet on a circuit different from that to which the receiver is connected.
- Consult the dealer or an experienced radio/TV technician for help.



FCC Caution: Any changes or modifications not expressly approved by the party responsible for compliance could void the user's authority to operate this equipment.

This device complies with Part 15 of the FCC Rules. Operation is subject to the following two conditions: (1) This device may not cause harmful interference, and (2) this device must accept any interference received, including interference that may cause undesired operation.

Note: This unit was tested with shielded cables on the peripheral devices. Shielded cables must be used with the unit to ensure compliance.

Industry Canada

This device complies with Industry Canada licence-exempt RSS standard(s). Operation is subject to the following two conditions: (1) this device may not cause interference, and (2) this device must accept any interference, including interference that may cause undesired operation of the device.

Le présent appareil est conforme aux CNR d'Industrie Canada applicables aux appareils radio exempts de licence. L'exploitation est autorisée aux deux conditions suivantes: (1) l'appareil ne doit pas produire de brouillage, et (2) l'utilisateur de l'appareil doit accepter tout brouillage radioélectrique subi, même si le brouillage est susceptible d'en compromettre le fonctionnement.

CE Declaration of Conformity



Manufacturer: Mikrotikls SIA, Brivibas gatve 214i Riga, Latvia, LV1039.

BG	С настоящото Mikrotikls SIA декларира, че този тип радиосъоръжение RouterBOARD е в съответствие с Директива 2014/53/ЕС. Цялостният текст на ЕС декларацията за съответствие може да се намери на следния интернет адрес: https://mikrotik.com/products
CS	Tímto Mikrotikls SIA prohlašuje, že typ rádiového zařízení RouterBOARD je v souladu se směrnicí 2014/53/EU. Úplné znění EU prohlášení o shodě je k dispozici na této internetové adrese: https://mikrotik.com/products
DA	Hermed erklærer Mikrotikls SIA, at radioudstyrstypen RouterBOARD er i overensstemmelse med direktiv 2014/53/EU. EU-overensstemmelseserklæringens fulde tekst kan findes på følgende internetadresse: https://mikrotik.com/products
DE	Hiermit erklährt Mikrotikls SIA, dass der Funkanlagentyp RouterBOARD der Richtlinie 2014/53/EU entspricht. Der vollständige Text der EU-Konformitätserklärung ist unter der folgenden Internetadresse verfügbar: https://mikrotik.com/products
EL	Με την παρούσα ο/η Mikrotikls SIA, δηλώνει ότι ο ραδιοεξοπλισμός RouterBOARD πληροί την οδηγία 2014/53/ΕΕ. Το πλήρες κείμενο της δήλωσης συμμόρφωσης ΕΕ διατίθεται στην ακόλουθη ιστοσελίδα στο διαδίκτυο: https://mikrotik.com/products
EN	Hereby, Mikrotikls SIA declares that the radio equipment type RouterBOARD is in compliance with Directive 2014/53/EU. The full text of the EU declaration of conformity is available at the following internet address: https://mikrotik.com/products
ES	Por la presente, Mikrotikls SIA declara que el tipo de equipo radioeléctrico RouterBOARD es conforme con la Directiva 2014/53/UE. El texto completo de la declaración UE de conformidad está disponible en la dirección Internet siguiente: https://mikrotik.com/products
ET	Käesolevaga deklareerib Mikrotikls SIA, et käesolev raadioseadme tüüp RouterBOARD vastab direktiivi 2014/53/EL nõuetele. ELi vastavusdeklaratsiooni täielik tekst on kättesaadav järgmisel internetiaadressil: https://mikrotik.com/products
FI	Mikrotikls SIA vakuuttaa, että radiolaitetyyppi RouterBOARD on direktiivin 2014/53/EU mukainen. EU-vaatimustenmukaisuusvakuutuksen täysimittainen teksti on saatavilla seuraavassa internetosoitteessa: https://mikrotik.com/products
FR	Le soussigné, Mikrotikls SIA, déclare que l'équipement radioélectrique du type RouterBOARD est conforme à la directive 2014/53/UE. Le texte complet de la déclaration UE de conformité est disponible à l'adresse internet suivante: https://mikrotik.com/products
HR	Mikrotikls SIA ovime izjavljuje da je radijska oprema tipa RouterBOARD u skladu s Direktivom 2014/53/EU. Cjeloviti tekst EU izjave o sukladnosti dostupan je na sljedećoj internetskoj adresi: https://mikrotik.com/products
HU	Mikrotikls SIA igazolja, hogy a RouterBOARD típusú rádióberendezés megfelel a 2014/53/EU irányelvnek. Az EU-megfelelőségi nyilatkozat teljes szövege elérhető a következő internetes címen: https://mikrotik.com/products
IT	Il fabbricante, Mikrotikls SIA, dichiara che il tipo di apparecchiatura radio RouterBOARD è conforme alla direttiva 2014/53/UE. Il testo completo della dichiarazione di conformità UE è disponibile al seguente indirizzo Internet: https://mikrotik.com/products
IS	Hér með lýsir Mikrotikls SIA því yfir að RouterBOARD er í samræmi við grunnkröfur og aðrar kröfur, sem gerðar eru í tilskipun 2014/53/EU. Fullur texti ESB samræmisýfirlýsingar er að finna á eftirfarandi veffangi: https://mikrotik.com/products
LT	Aš, Mikrotikls SIA, patvirtinu, kad radijo įrenginių tipas RouterBOARD atitinka Direktyvą 2014/53/ES. Visas ES atitikties deklaracijos tekstas prieinamas šiuo interneto adresu: https://mikrotik.com/products
LV	Ar šo Mikrotikls SIA deklarē, ka radioiekārta RouterBOARD atbilst Direktīvai 2014/53/ES. Pilns ES atbilstības deklarācijas teksts ir pieejams šādā interneta vietnē: https://mikrotik.com/products
MT	B'dan, Mikrotikls SIA, niddikjara li dan it-tip ta' taghmir tar-radju RouterBOARD huwa konformi mad-Direttiva 2014/53/UE. It-test kollu tad-dikjarazzjoni ta' konformità tal-UE huwa disponibbli f'dan l-indirizz tal-Internet li ġej: https://mikrotik.com/products
NL	Hierbij verklaar ik, Mikrotikls SIA, dat het type radioapparatuur RouterBOARD conform is met Richtlijn 2014/53/EU. De volledige tekst van de EU-conformiteitsverklaring kan worden geraadpleegd op het volgende internetadres: https://mikrotik.com/products
NO	Mikrotikls SIA erklærer herved at utstyret RouterBOARD er i samsvar med de grunnleggende krav og øvrige relevante krav i direktiv 2014/53/EU. Den fulle teksten til EU-samsvarserklæringen er tilgjengelig på følgende internetadresse: https://mikrotik.com/products
PL	Mikrotikls SIA niniejszym oświadcza, że typ urządzenia radiowego RouterBOARD jest zgodny z dyrektywą 2014/53/UE. Pełny tekst deklaracji zgodności UE jest dostępny pod następującym adresem internetowym: https://mikrotik.com/products
PT	O(a) abaixo assinado(a) Mikrotikls SIA declara que o presente tipo de equipamento de rádio RouterBOARD está em conformidade com a Diretiva 2014/53/UE. O texto integral da declaração de conformidade está disponível no seguinte endereço de Internet: https://mikrotik.com/products
RO	Prin prezenta, Mikrotikls SIA declară că tipul de echipamente radio RouterBOARD este în conformitate cu Directiva 2014/53/UE. Textul integral al declarației UE de conformitate este disponibil la următoarea adresă internet: https://mikrotik.com/products
SK	Mikrotikls SIA týmto vyhlasuje, že rádiové zariadenie typu RouterBOARD je v súlade so smernicou 2014/53/EÚ. Úplné EÚ vyhlásenie o zhode je k dispozícii na tejto internetovej adrese: https://mikrotik.com/products
SL	Mikrotikls SIA potrjuje, da je tip radijske opreme RouterBOARD skladen z Direktivo 2014/53/EU. Celotno besedilo izjave EU o skladnosti je na voljo na naslednjem spletnem naslovu: https://mikrotik.com/products
SV	Härmed försäkrar Mikrotikls SIA att denna typ av radioutrustning RouterBOARD överensstämmer med direktiv 2014/53/EU. Den fullständiga texten till EU-försäkran om överensstämmelse finns på följande webbadress: https://mikrotik.com/products

Note. Information contained here is subject to change. Please visit the product page on www.mikrotik.com for the most up to date version of this document.



BG. Инструкции: Свържете адаптера на захранване, за да включите устройството. Отворете 192.168.88.1 в уеб браузър, за да настроите продукта. Повече информация в <http://mt.lv/help-bg>

CS. Návod k použití: Připojte napájecí adaptér k zapnutí přístroje. Otevřete 192.168.88.1 ve webovém prohlížeči pro konfiguraci produktu. Více informací najdete v <http://mt.lv/help-cs>

DA. Instruktionsbog: Tilslut strømadapteren for at tænde for enheden. Åbn 192.168.88.1 i en webbrowser til at konfigurere produktet. Mere information i <http://mt.lv/help-da>

DE. Bedienungsanleitung: Verbinden Sie das Netzteil, um das Gerät einzuschalten. Öffnen Sie 192.168.88.1 in einem Web-Browser, um das Produkt zu konfigurieren. Weitere Informationen im <http://mt.lv/help-de>

EL. εγχειρίδιο οδηγιών: Συνδέστε τον προσαρμογέα τροφοδοσίας για να ενεργοποιήσετε τη μονάδα. Ανοίξτε 192.168.88.1 σε ένα πρόγραμμα περιήγησης στο Web για να διαμορφώσετε το προϊόν. Περισσότερες πληροφορίες στο <http://mt.lv/help-el>

EN. Instruction manual: Connect the power adapter to turn on the device. Open 192.168.88.1 in your web browser, to configure it. More information on <http://mt.lv/help>

ES. Manual de instrucciones: Conecte el adaptador de alimentación para encender la unidad. Abra 192.168.88.1 en un navegador web para configurar el producto. Más información en <http://mt.lv/help-es>

ET. Kasutusjuhend: Ühendage toiteadapter seadme sisselülitamiseks. Avatud 192.168.88.1 in veebilehitseja seadistada toodet. Rohkem teavet <http://mt.lv/help-et>

FI. Käyttöohje: Kytke virtalähde päälle laitteen. Avaa 192.168.88.1 in selaimen määrittää tuotteen. Lisää tietoa <http://mt.lv/help-fi>

FR. Mode d'emploi: Connectez l'adaptateur d'alimentation pour allumer l'appareil. Ouvrez 192.168.88.1 dans un navigateur Web pour configurer le produit. Plus d'informations dans <http://mt.lv/help-fr>

HR. Uputa za uporabu: Priključite napajanje i uključite uređaj. Za konfiguraciju uređaja u pregledniku otvorite 192.168.88.1. Više informacija je na <http://mt.lv/help-hr>

HU. Használati utasítás: Csatlakoztassa a hálózati adaptert a készülék bekapcsolásához. Megnyitása 192.168.88.1 egy webböngészőben beállítani a terméket. Több információ <http://mt.lv/help-hu>

IT. Manuale di istruzioni: Collegare l'adattatore di alimentazione per accendere l'unità. Aprire 192.168.88.1 in un browser Web per configurare il prodotto. Maggiori informazioni in <http://mt.lv/help-it>

IS. Notkunarleiðbeiningar: Tengdu straumbreytinn til að kveikja á tækinu. Opnaðu 192.168.88.1 í vafra til að stilla það. Nánari upplýsingar á <http://mt.lv/help-is>

NO. Instruksjonsmanual: Koble strømadapteren for å slå på enheten. Åpne 192.168.88.1 i nettleseren din for å konfigurere den. Mer informasjon på <http://mt.lv/help-no>

LT. Naudojimosi instrukcija: Prijunkite maitinimo adapterį įjunkite įrenginį. Į interneto naršyklę 192.168.88.1 Atidarykite galite konfigūruoti gaminį. Daugiau informacijos rasite <http://mt.lv/help-lt>

LV. Lietošanas instrukcija: Pievienojiet Strāvas adapteri, lai ieslēgtu ierīci. Atvērt 192.168.88.1 ar interneta pārlūku, lai konfigurētu produktu. Plašāka informācija <http://mt.lv/help-lv>

MT. Manwal tal-istruzzjoni: Qabbad l-adapter tal-qawwa biex iddawwar it-tagħmir. Iftaħ 192.168.88.1 fil-web browser tiegħek, biex jiġi kkonfigurati. Aktar informazzjoni fuq <http://mt.lv/help-mt>

NL. Handleiding: Sluit voedingsadapter aan op het apparaat in te schakelen. Open 192.168.88.1 in een webbrowser om het product te configureren. Meer informatie in <http://mt.lv/help-nl>

PL. Instrukcja obsługi: Podłącz adapter zasilania, aby włączyć urządzenie. Otwórz 192.168.88.1 w przeglądarce internetowej, aby skonfigurować urządzenie. Więcej informacji w <http://mt.lv/help-pl>

PT. Manual de instruções: Conecte o adaptador de alimentação para ligar o aparelho. Abra 192.168.88.1 em um navegador da web para configurar o produto. Mais informações em <http://mt.lv/help-pt>

RO. Instrucțiuni de utilizare: Conectați adaptorul de alimentare pentru a porni aparatul. Deschide 192.168.88.1 într-un browser web pentru a configura produsul. Mai multe informații în <http://mt.lv/help-ro>

SK. Navodila: Priključite napajalnik za vklop naprave. Odprite 192.168.88.1 v spletnem brskalniku nastaviti izdelek. Več informacij v <http://mt.lv/help-sk>

SL. Návod na použitie: Pripojte napájací adaptér k zapnutiu prístroja. Otvorte 192.168.88.1 vo webovom prehliadači pre konfiguráciu produktu. Viac informácií nájdete v <http://mt.lv/help-sl>

SV. Instruktionsmanual: Anslut nätadaptern för att slå på enheten. Öppna 192.168.88.1 i en webbläsare för att konfigurera produkten. Mer information på <http://mt.lv/help-sv>

NO. Bruksanvisningen: Koble strømadapteren for å slå på enheten. Åpne 192.168.88.1 i en nettleaser for å konfigurere produktet. Mer informasjon på <http://mt.lv/help-no>

RU. Руководство по эксплуатации: подключите адаптер питания чтобы включить устройство. Откройте 192.168.88.1 в своем веб-браузере для конфигурации. Дополнительная информация <http://mt.lv/help-ru>

CN. 说明书: 连接电源适配器以打开设备。在 Web 浏览器中打开 192.168.88.1 进行配置。有关 <http://mt.lv/help-zh> 的更多信息